

# Performance Curve

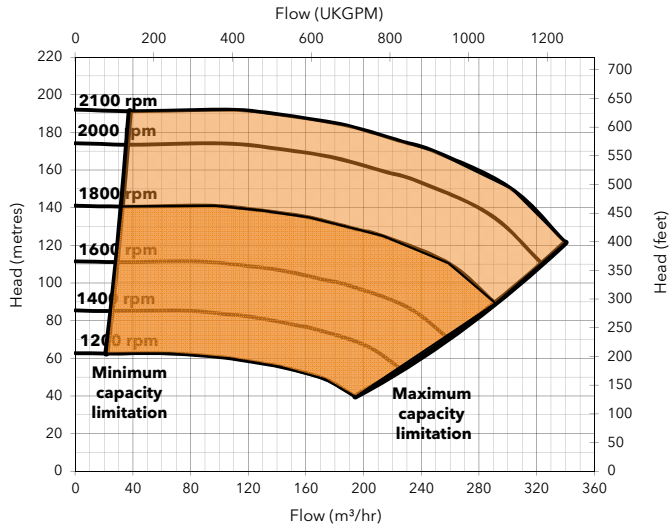

## Engine option 1

Price list ref - HL130M-01-DBO-001

Caterpillar, C9, 205.0 kW @ 2100 rpm

Impeller diameter 514 mm

Pump Speed 2100 rpm

### Suction Lift Table

Total Suction Head (metres)	Total Delivery Head (metres)				
	111	149	160	171	182
	Output (m³/hr)				
3.0	341	299	268	229	153
4.6	336	294	263	226	143
6.1	331	294	252	210	134
7.6	326	294	263	189	105

Fuel capacity (Full) 850 litres, (Usable) 690 litres

Fuel consumption @ 2100 rpm BEP 52 litres/hour

Weight: (Dry) 4,600 kg, (Wet) 5,331 kg

Dimensions: (L) 3,700 x (W) 1,700 x (H) 2,200 mm

Performance data provided in tables is based on water tests at sea level and 20°C ambient. All information is approximate and for general guidance only. Please contact the factory or office for further details.

# Materials

Pump casing & suction cover	Cast iron BS EN 1561 - 1997
Wearplates	High Chromium Cast Iron HC403:1977 Grade FR6252
Pump Shaft	Carbon steel BS EN 1561 - 1997
Impeller	Cast Steel BS3100 A5 Hardness to 200 HB Brinell
Non-return Valve body	Steel BS EN 1561 - 1997
Mechanical Seal Faces	Silicon carbide vs silicon carbide

## Engine option 2

Price list ref - HL130M-01-DBO-002

Volvo, TAD950VE, 181.0 kW @ 1800 rpm

Impeller diameter 514 mm

Pump Speed 1800 rpm

### Suction Lift Table

Total Suction Head (metres)	Total Delivery Head (metres)				
	79	107	115	123	131
	Output (m³/hr)				
3.0	293	257	230	196	131
4.6	288	252	225	194	122
6.1	284	252	216	180	115
7.6	279	252	225	162	90

Fuel capacity (Full) 850 litres, (Usable) 690 litres

Fuel consumption @ 1800 rpm BEP 35 litres/hour

Weight: (Dry) 5,000 kg, (Wet) 5,744 kg

Dimensions: (L) 3,700 x (W) 1,700 x (H) 2,200 mm

Performance data provided in tables is based on water tests at sea level and 20°C ambient. All information is approximate and for general guidance only. Please contact the factory or office for further details.

HL130M - Caterpillar C9

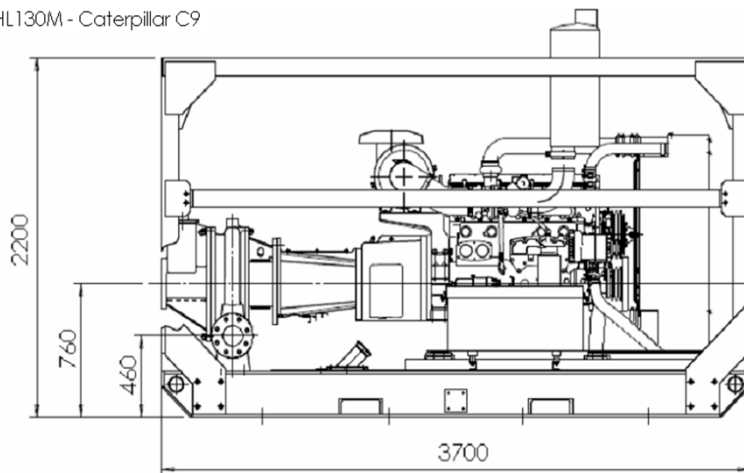
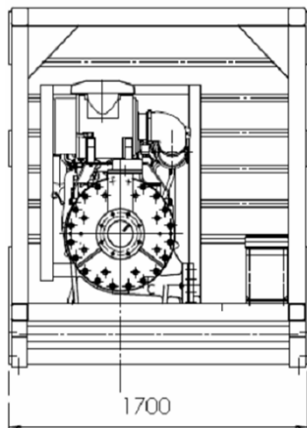

Xylem Dewatering Solutions UK Ltd  
 Quenington, Cirencester  
 Gloucestershire GL7 5BX, England  
 Tel: 01285 750271 Fax: 01285 750352



Assessed to ISO 9001:2008  
 Certificate N° 1027

Reference number : 95-1116-1000  
 Date of issue : 05 December 2012  
 Issue : 13

[www.godwinpumps.com](http://www.godwinpumps.com)