

Cable
Heavy duty, rubber sheathed cables to BS 7919.

Bearings
Pre-lubricated angular contact thrust bearings & deep groove ball journal bearings. Designed for extended life.

Instrumentation
Thermal overload thermistors, embedded in motor windings, and seal leakage sensors fitted as standard. Optional bearing temperature probes.

Mechanical Seals
Two high quality, independently mounted, seals in an oil-filled enclosure to prevent water ingress to motor.

Pump Casing
Cast Iron construction with easily renewable wear ring. A handhole is included as standard in dry-well versions.

Terminal Box
High integrity IP68 design. Easy access to terminal plate without removing cables. Alternative cable entry positions to facilitate cable layout on site. Also available for EN50 019 (EExe) requirements.

Motor
High efficiency squirrel cage induction design to BS 4999, Class F insulation. Suitable for: star delta, D.O.L., inverter or auto-transformer starting. Enclosures designed to EN50 018 (EExd) are available.

Motor Cooling
For Dry-Well or exposed motors in Wet-Well installations, cooling is effected by heat transfer oil circulated around the motor casing by an auxiliary impeller, mounted between the mechanical seals. The oil is cooled by the pumped fluid in conjunction with a special cover/heat exchanger. This totally sealed system is separate from the pumped media and does not normally require any external cooling.

Impeller
High efficiency, shrouded design of cast construction. Capable of handling solids & fibrous material. Statically & dynamically balanced prior to assembly.

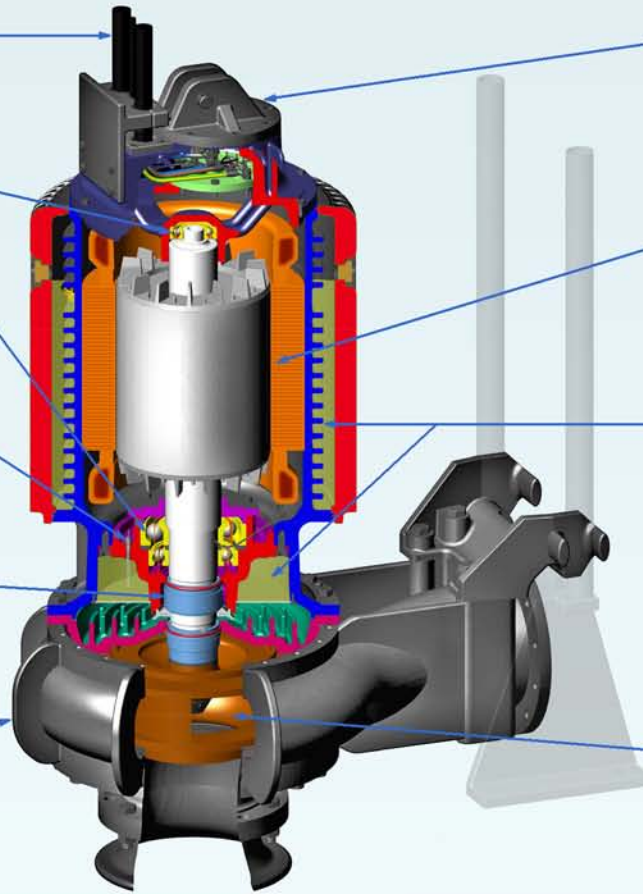

Materials of Construction

- Motor casing - SG Cast Iron BS 2789 Grade 420/12
- Pump Casing - SG Cast Iron BS 2789 Grade 420/12
- Casing Wear Ring - SG Cast Iron BS 2789 Grade 420/12
- Cast Components - Cast Iron BS EN 1561 Grade 250
- Pump Shaft - Carbon Steel BS 970 070 M20
- Impeller - SG Cast Iron BS 2789 Grade 420/12

Alternative material options and seal face combinations are available.

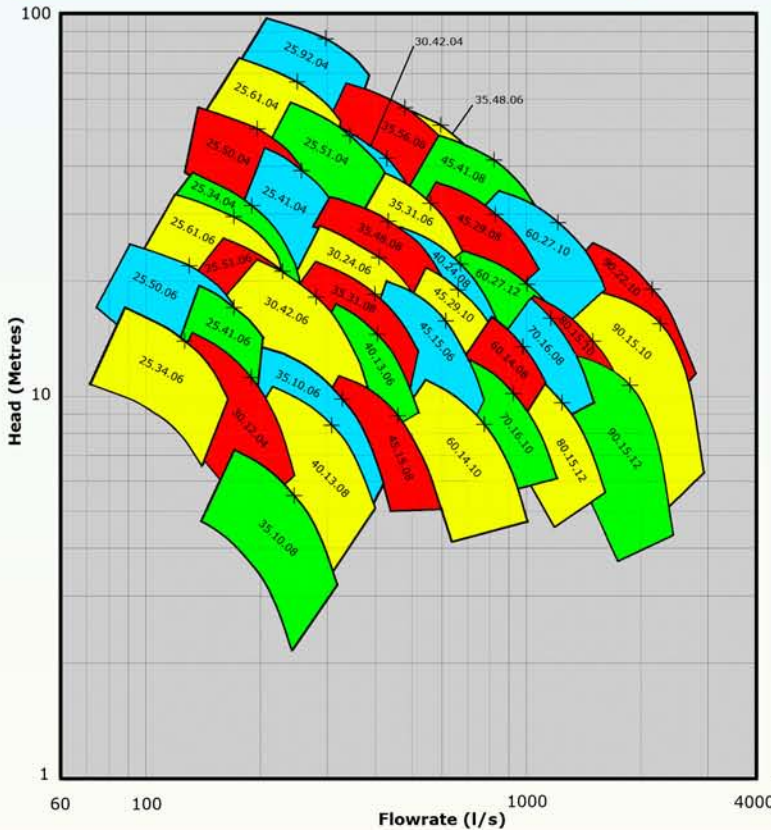

Typical Arrangements

This versatile pump can be installed either totally submerged in a wet well or in a dry chamber.

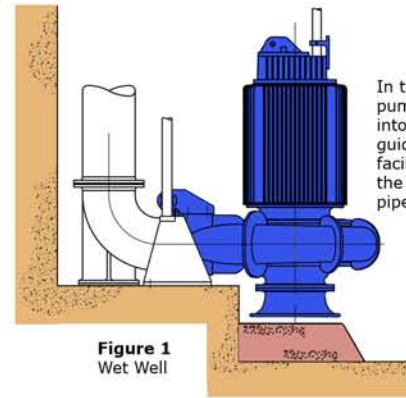

Figure 1
Wet Well

In the wet well installation, pumps are raised and lowered into the sump via guide rails or guide wires. A docking flange facilitates automatic coupling of the pump to the discharge pipework.

When installed in a dry chamber, the pump is bolted directly to the suction and discharge pipework. It is supported on feet and mounted on two concrete plinths or directly onto a duckfoot bend.

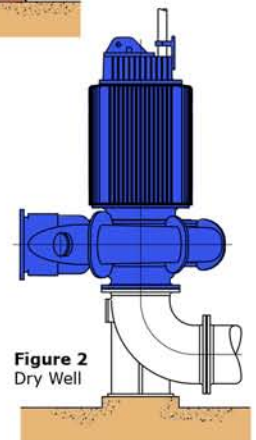

Figure 2
Dry Well



BEDFORD PUMPS LTD.
Part of the *Hydrotal* group of companies

Brooklands Woburn Road Industrial Estate, Kempston, Beds. MK42 7UH Tel: +44 (0)1234 852071
Fax: +44 (0)1234 856620 email: sales@bedfordpumps.co.uk Web: www.bedfordpumps.co.uk

